

CDD12J-K Electric pallet stacker

Characteristics:

1. High-power and high-performance lifting pump has high efficiency.
2. Side driving design gives the truck a small steering radius and broadened view.
3. The driving system with permanent magnetic motor has small volume, light mass, small loss.
4. Water-proof inching switch imported from German meets the requirements of harsh working condition such as cold, humidity and dust circumstances.
5. Four colors LED electricity meter makes it simple and direct to read.
6. External positioned charger has better cooling performance.
7. It's more comfortable and easy for operation using a super long handle that integrates lifting button, key switch, electricity meter, which is suitable for ergonomics; more accurate speed control with the turtle speed switch; more durable with the high quality air-pressure springs which allows slowly and automatically reset.
8. Iron steel guard with high density is durable, firm and has high protection effect.
9. Adjustable wide leg is suitable for different sizes of pallets and it is safer and more reliable.



Manufacturer's Data and Design Characteristics

Characteristics							
1.01	Manufacturer	HELI					
1.02	Model	CDD12J-K					
1.03	Operation	Pedestrian propelled					
1.04	Rated traction weight	Q (kg)	1200				
1.05	Mast type	Single mast	2-Stage STD				
1.06	Lift	h3 (mm)	1600	2000	2500	3000	3500
1.07	Capacity at highest height	kg	1200	1050	900	750	600
1.08	Service weight with battery	kg	595	636	648	660	672
1.09	Load centre	c (mm)	600				
1.10	Axle centre to fork face	x (mm)	698				
1.11	Wheel base	y (mm)	1170				
1.12	Controller	CURTIS					
Wheels/Tyres							
2.01	Wheels type	Polyurethane					
2.02	Driving wheel size	Φ×w(mm)	Φ210×70				
2.03	Bearing wheel size	Φ×w(mm)	Φ80×70				
2.04	Additional wheels(dimensions)	Φ×w(mm)	Φ115×55				
2.05	Wheels, number front/rear(x = driven)	1x+1/4					
Dimensions							
3.01	Height of mast, lowered	h1 (mm)	2099	1580	1830	2080	2330
3.02	Height of mast, extended	h4 (mm)	2099	2549	3049	3549	4049
3.03	Fork Height, Lowered	h13 (mm)	65				
3.04	Overall length	l1 (mm)	1769				
3.05	Length to fork face	l2 (mm)	619				
3.06	Overall width	b1/ b2 (mm)	1148-1548				
3.07	Fork dimensions	s/e/l (mm)	35/100/1150				
3.08	Width of forks	b5 (mm)	210-850				
3.09	Width of Leg	b6 (mm)	124				
3.10	Min.Ground clearance	m2 (mm)	26				
3.11	Aisle width with pallet 1000 x 1200 across forks	Ast (mm)	2210				
3.12	Aisle width with pallet 800 x 1200 along forks	Ast (mm)	2180				
3.13	Min.Turning radius	1346					
Performance							
4.01	Travel speed, with/without load	(km/h)	4.0/4.2				
4.02	Lifting speed, with/without load	(mm/s)	92/136				
4.03	Lowering speed, with/without load	(mm/s)	112/98				
4.04	Max. gradeability laden/unladen	(%)	4/8				
4.05	Service brake	Electromagnetic brake					
Drive							
5.01	Drive motor, output S2 60 min.	(kW)	0.75				
5.02	Lift motor rating at S3 15%	(kW)	2.2				
5.03	Battery according to DIN 43531/35/36 A,B,C,no	no					
5.04	Battery voltage/rated capacity	(V/Ah)	2×12/100				
5.05	Battery weight (± 5%)	(kg)	2×27				
Others							
6.01	Noise level at operator's ear	(dB(A))	≤70				
6.02	Steering type	Mechanical steering					

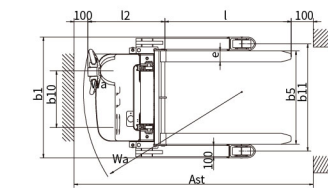
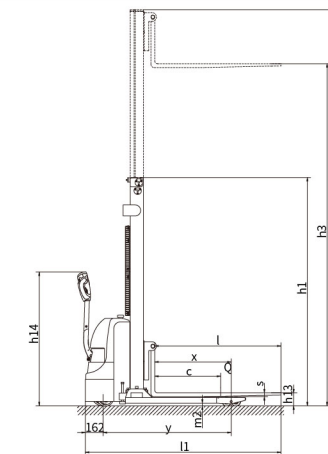

ANHUI HELI CO., LTD.

Add / No.668, FangXing Road, Hefei, China
Fax / +86-551-63639966

Tel / +86-551-63639068(America); 63639258(Europe);
63639358(Asia); 63662105(Africa & Middle East);
63639530(Key Accounts Division); 63662105(Wheel loader)