

HELI

CBD15J/18J/20J-Li2

Lithium Battery Powered Pallet Truck

Characteristics:

- The truck is simple and dexterous, with small turning radius and small weight. It is suitable for ultra-narrow channel operation.
- The truck has compact and reliable structure. The oil pipeline and line are wrapped in the truck body which is safe and beautiful and convenient for user maintenance.
- The truck adopts integrated handle design integrating key switch and electric meter which is simple and comfortable for operation.
- Hand-held lithium battery makes battery changing easier and more convenient.
- Standard configuration of emergency stop switch and emergency reverse device ensure truck safety.
- The truck is assembled with power-off braking function. The truck is braked as soon as the handle is loosened or pressed to the bottom.
- Electromagnetic braking and motor braking are used to ensure the safety of driving.
- Option: intelligent handle with electricity meter、PIN code entry and turtle speed button integrated, realize the function of upright-walking in narrow spaces and operate more comfortably.



Manufacturer's Data and Design Characteristics

Characteristics		HELI	HELI	HELI
1.1	Manufacturer		HELI	HELI
1.2	Model		CBD15J-Li2	CBD18J-Li2
1.3	Type of operation		Pedestrian	Pedestrian
1.4	Rated capacity	Q (kg)	1500	1800
1.5	Lift height	h3 (mm)	200	200
1.6	Service weight with battery	kg	138	140
1.7	Load centre	c (mm)	600	600
1.8	Axle centre to fork face	x (mm)	944	944
1.9	Wheel base	y (mm)	1184	1184
1.10	Controller		CURTIS	CURTIS
Wheels				
2.1	Wheels type		Polyurethane	Polyurethane
2.2	Driving wheels size	Φ×w(mm)	Φ210×70	Φ210×70
2.3	Loading wheels size	Φ×w(mm)	Φ80×60	Φ80×60
2.4	wheels, number front/rear (x = driven)		1x/4	1x/4
2.5	track width, rear, loading side	b11 (mm)	400/535	400/535
Dimensions				
3.1	Overall length	l1 (mm)	1543	1543
3.2	Length to fork face	l2 (mm)	393	393
3.3	Overall width	b1 (mm)	550/685	550/685
3.4	Fork dimensions	s/e/l (mm)	50/150/1150	50/150/1150
3.5	Width of forks	b5 (mm)	550/685	550/685
3.6	Lowered height	h13 (mm)	85	85
3.7	Min.Ground clearance	m2 (mm)	35	35
3.8	Height drawbar in driving position min./max.	h14 (mm)	830/1120	830/1120
3.9	Aisle width with pallet 1000 x 1200 across forks	Ast (mm)	1760	1760
3.10	Aisle width with pallet 800 x 1200 along forks	Ast (mm)	1810	1810
3.11	Min.Turning radius	Wa (mm)	1355	1355
Performance				
4.1	Travel speed,with/without load	(km/h)	4.2/4.5	4.2/4.5
4.2	Max. Gradeability laden/unladen	(%)	5/10	4/10
4.3	Service brake type		Electromagnetic brake	Electromagnetic brake
Drive and Battery				
5.1	Drive motor,output s2 60 min.	(kW)	0.75	0.75
5.2	Lift motor rating at s3 15%	(kW)	0.8	0.8
5.3	Battery according to din 43531/35/36 a,b,c,no		no	no
5.4	Battery voltage/rated capacity	(V/Ah)	24/28 (LFP)	24/28 (LFP)
5.5	Battery weight (± 5%)	(kg)	6.8	7.5
5.6	Charger specification		24V/10A (LFP)	24V/10A (LFP)
Others				
6.1	Type of drive control		DC	DC
6.2	Sound pressure level at driver 's ear	(dB(A))	≤70	≤70
6.3	Steering type		Mechanical steering	Mechanical steering

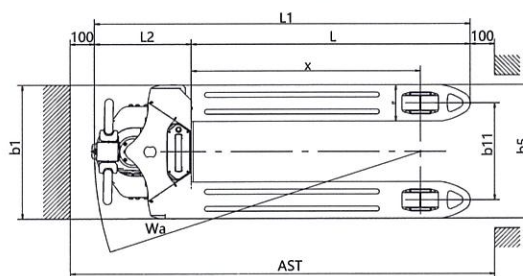
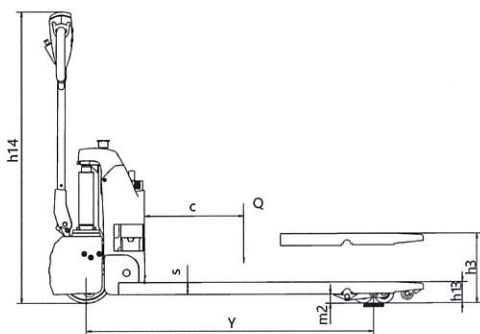

Design&Print:Fokeli Printing 20220309



ANHUI HELI CO., LTD.

Add / No.668, FangXing Road, Hefei, China

Fax / +86-551-63639966

Tel / +86-551-63639068(America); 63639258(Europe); 63639358(Asia);

63662105(Africa & Middle East); 63639530(Overseas Marketing)



LinkedIn



YouTube



Facebook